

永磁直流行星齿轮电机 PM DC PLANETARY GEAR MOTOR

42JXT200K/42ZY75

Φ42 超大力矩型减速器, 允许转矩范围: 2N.m~20N.m

42mm OD Large Torque Gearbox, Permissible Load Range: 2N.m~20N.m

42JXGT200K/42ZY75

Φ42 长寿命、超大力矩型减速器, 允许转矩范围: 2N.m~20N.m

42mm OD Long Life & Large Torque Gearbox, Permissible Load Range: 2N.m~20N.m

● 外形和安装尺寸 Dimensions

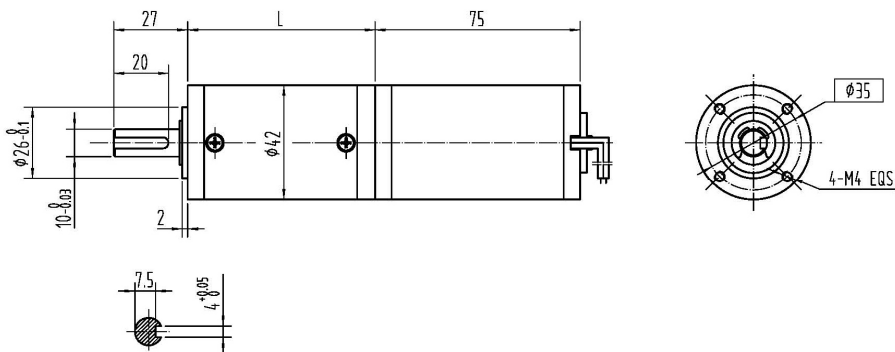

● 电动机主要技术参数 Motor Technical Data

电机型号 TYPE	额定电压 Rated voltage VDC	空载转速 No-load speed r/min	空载电流 No-load current A	额定转速 Rated speed r/min	额定转矩 Rated torque m.Nm	输出功率 Output power W	额定电流 Rated current A	堵转力矩 Stall torque m.Nm	堵转电流 Stall current A
42ZY75-2420	24	2000	0.10	1600	35	5.9	0.42	183	1.73
42ZY75-2430	24	3000	0.15	2500	44	11.5	0.75	259	3.55
42ZY75-2440	24	4000	0.20	3400	50	17.8	1.10	336	6.09

● 齿轮减速电机主要技术参数 Gear motor Technical Data

配置 42ZY75-2420 直流电机 (42ZY75-2420 DC Motor)

减速比 Reduction ratio	65	83	106	247	316	403	515	944	1026
减速级数 Number of gear trains	3	3	3	4	4	4	4	5	5
减速器长度(L) Length(L) mm	60.5	60.5	60.5	70.9	70.9	70.9	70.9	81.2	81.2
空载转速 No-load speed r/min	31	24	19	8.1	6.3	5.0	3.9	2.1	1.7
额定转速 Rated speed r/min	25	19	15	6.5	5.1	4.0	3.1	1.7	1.3
额定转矩 Rated torque N.m	1.7	2.1	2.7	5.6	7.2	9.2	12	19	20
最大瞬间允许负载 Max. permissible load in a short time N.m	25	25	25	50	50	50	50	60	60

配置 42ZY75-2430 直流电机 (42ZY75-2430 DC Motor)

减速比 Reduction ratio	65	83	106	247	316	403	515	944
减速级数 Number of gear trains	3	3	3	4	4	4	4	5
减速器长度(L) Length(L) mm	60.5	60.5	60.5	70.9	70.9	70.9	70.9	81.2
空载转速 No-load speed r/min	46	36	28	12	9.5	7.4	5.8	3.2
额定转速 Rated speed r/min	38	30	24	10	7.9	6.2	4.9	2.6
额定转矩 Rated torque N.m	2.1	2.7	3.4	7.1	9.0	12	15	20
最大瞬间允许负载 Max. permissible load in a short time N.m	25	25	25	50	50	50	50	60

配置 42ZY75-2440 直流电机 (42ZY75-2440 DC Motor)

减速比 Reduction ratio	65	83	106	247	316	403	515	944
减速级数 Number of gear trains	3	3	3	4	4	4	4	5
减速器长度(L) Length(L) mm	60.5	60.5	60.5	70.9	70.9	70.9	70.9	81.2
空载转速 No-load speed r/min	62	48	38	16	13	9.9	7.8	4.2
额定转速 Rated speed r/min	52	41	32	14	11	8.4	6.6	3.6
额定转矩 Rated torque N.m	2.4	3.0	3.9	8.0	10	13	17	20
最大瞬间允许负载 Max. permissible load in a short time N.m	25	25	25	50	50	50	50	60